



Manual de instrucciones
Instruction manual
Manuel d'instruction
Betriebsanleitung
Manuale di funzionamento

D I G I T A L
IKM10-0329-02



IKM10-0329-02

DIGITAL

■ MANUAL DE INSTRUCCIONES	1
■ INSTRUCTION MANUAL	19
■ MANUEL D'INSTRUCTION	37
■ BETRIEBSANLEITUNG	55
■ MANUALE DI FUNZIONAMENTO	73

1. MODO DE VISUALIZACIÓN Y OPERACIÓN DE LOS BOTONES

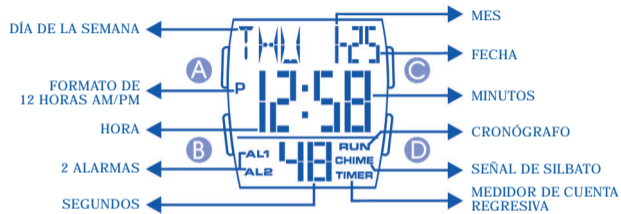

OPERACIÓN DE BOTÓN

A AJUSTE, REAJUSTE

B MODO

C AJUSTE, INICIO / PARADA

D LUZ / INVERSO

2. COMO CAMBIAR EL MODO DE VISUALIZACIÓN

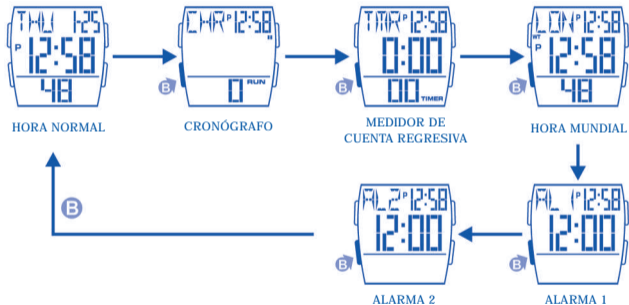

3. COMO USAR LA LUZ

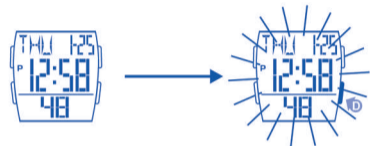

AVISO:

- 1) La iluminación del reloj utiliza una luz electroluminiscente (EL) que tiende a perder potencia después de usos muy prolongados.
- 2) Bajo la luz solar directa es difícil ver la iluminación que proporciona la luz de la pantalla.

4. AJUSTE DE LA HORA NORMAL

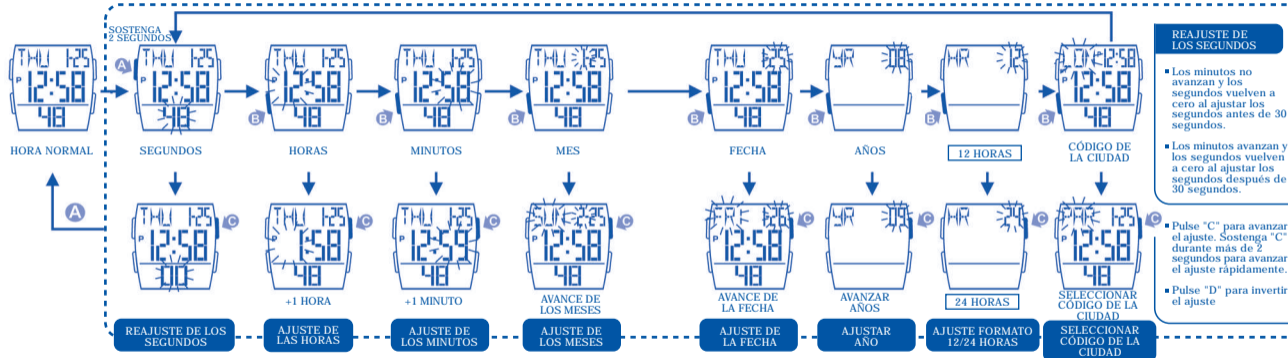

5. AJUSTE DE LA ALARMA

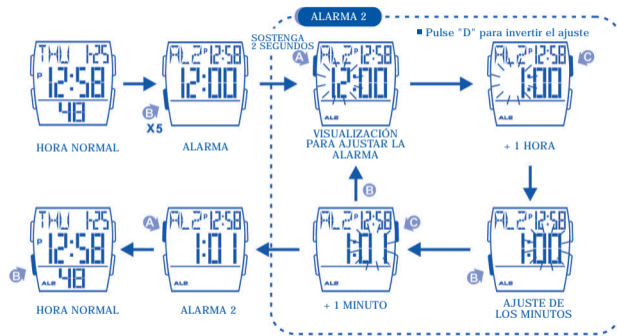
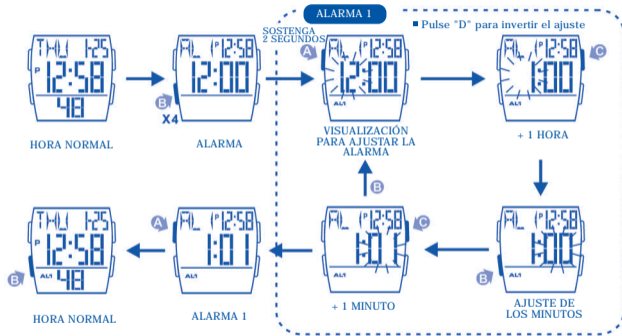

6. AJUSTE DE LA ALARMA-1 Y SEÑAL HORARIA (ENCENDIDA/APAGADA)

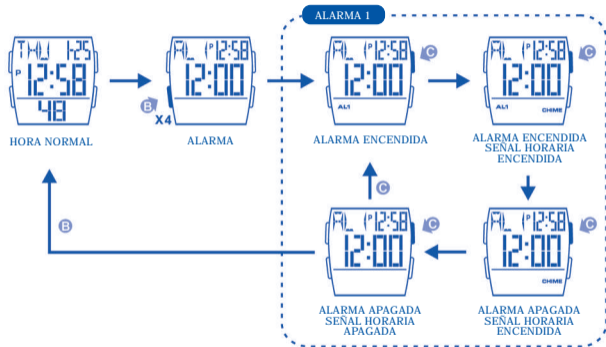

7. COMO AJUSTAR LA PRESENTACIÓN DE LA ALARMA 2

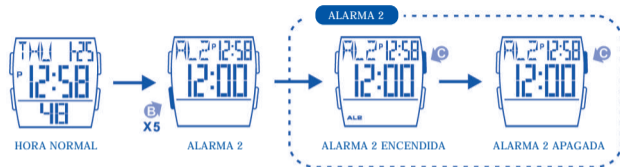

8. COMO UTILIZAR EL CRONÓGRAFO



ANTES DE LOS
30 MINUTOS



DESPUÉS DE LOS
30 MINUTOS

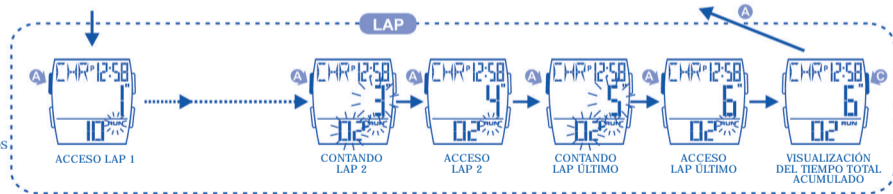

9. COMO UTILIZAR EL MEDIDOR DE CUENTA REGRESIVA

AJUSTE DEL TEMPORIZADOR PARA LA CUENTA ATRÁS



Cuando el temporizador alcanza cero, la alarma emite tres pitidos "BI-BI-BI" durante 10 segundos. Puede silenciar la alarma pulsando cualquier botón, de lo contrario, realizará el conteo progresivo hasta 5 minutos.

CONTEO PROGRESIVO

Durante los últimos 10 segundos del conteo regresivo, la alarma emitirá un pitido (BI) por segundo.

■ Presione el botón C para iniciar y parar.

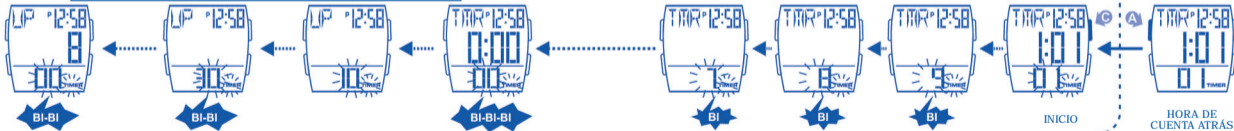

10. COMO AJUSTAR LA HORA MUNDIAL



Diferencia de GMT	-11	-10	-09	-08	-07	-06	-05	-04	-03	-00	+01	+02	+03	+04	+05	+06	+07	+08	+09	+10	+11	+12
CÓDIGO DE LA CIUDAD	PPG	HNL	ANC	LAX	DEN	MEX	NYC	CCS	RIO	LON	PAR	CAI	MOW	DXB	KHI	DAC	BKK	HKG	TYO	SYD	NOU	WLG
NOMBRE DE LA CIUDAD	Samoa	Honolulu	Anchorage	Los Angel	Denver	Mexico	New York	Caracas	Rio De Janeiro	London	Paris	Cairo	Moscow	Dubai	Karachi	Dacca	Bangkok	Hong Kong	Tokyo	Sydney	Noumea	Wellington

11. CUIDADO DE SU RELOJ

- 1) Este reloj contiene componentes electrónicos. No intente abrir la caja o remover la tapa posterior.
- 2) No oprimir los botones de su reloj bajo la superficie del agua, nadando o practicando submarinismo.
- 3) Si por cualquier motivo llegase a aparecer agua o condensación en el reloj hágalo chequear inmediatamente. El agua puede corroer los componentes electrónicos dentro de la caja.
- 4) Evite impactos severos. El reloj está diseñado para resistir impactos bajo condiciones normales de uso. Se sugiere no someterlo a impactos severos, al uso inadecuado o caídas bruscas sobre superficies duras.
- 5) Evite exponer el reloj a temperaturas extremas.
- 6) Limpie su reloj únicamente con agua y un paño suave. Evite el uso de productos químicos especialmente de jabón.
- 7) Mantenga su reloj lejos de cualquier campo eléctrico o estático.

12. CARACTERÍSTICAS Y ESPECIFICACIONES

- 1) Modo de tiempo: hora, minutos, segundos, mes, fecha y día de la semana.
- 2) Función:
 - Años, meses, fecha AM/PM y luz electroluminiscente.
 - Alarma: Funciona con el sonido de buzzer.
 - Cronómetro: Funciona con operación repetida.
 - Formato de 12/24 horas.
 - Segunda zona horaria.
 - Señal horaria encendida o apagada.
 - Hora mundial.
 - Contador de cuenta regresiva.
- 3) Precisión a temperaturas normales (25°C): ± 30 segundos por mes.
- 4) Rango de temperatura de operación normal: 10°C - 40°C



En aplicación de la normativa sobre los desechos de equipos eléctricos y electrónicos, los productos de relojería de cuarzo que se encuentran al final de su vida útil deben ser sometidos a una recogida selectiva en vistas a su posterior tratamiento. También puede depositar nuestros productos de relojería de cuarzo en uno de nuestros puntos de venta autorizados, así como en cualquier punto de recogida habilitado. La recogida selectiva, el tratamiento, la valoración y el reciclaje contribuyen a la salvaguarda de nuestro medio ambiente y a la protección de nuestra salud.

1. REGULAR DISPLAY AND BUTTON OPERATION

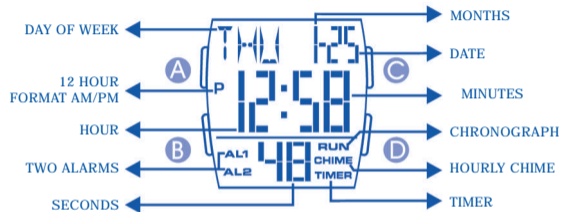

BUTTON OPERATION

A SET

B MODE

C ADJUST, START / STOP

D LIGHT

2. HOW TO CHANGE THE DISPLAY MODE

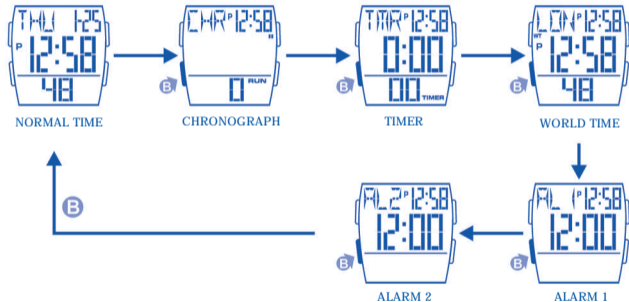

3. HOW TO USE EL LIGHT

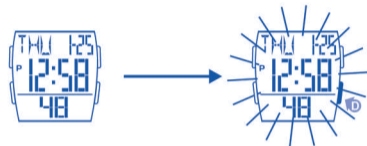

NOTE:

- 1) The backlight of the watch employs an electro-luminescent (EL) light, watch tends to lose illuminating power after very long use.
- 2) The illumination provided by backlight may be hard to see when viewed under direct sunlight.

4. HOW TO SET NORMAL TIME

English

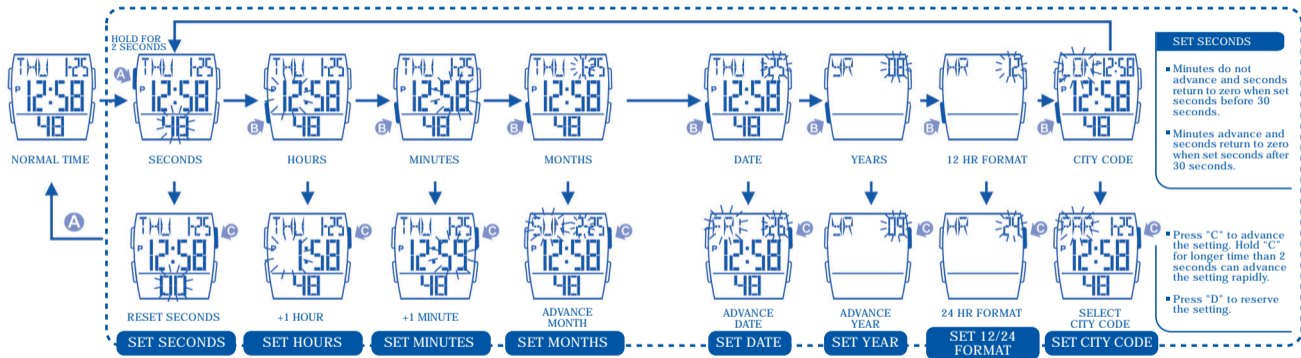

English

5. HOW TO SET ALARM TIME

English

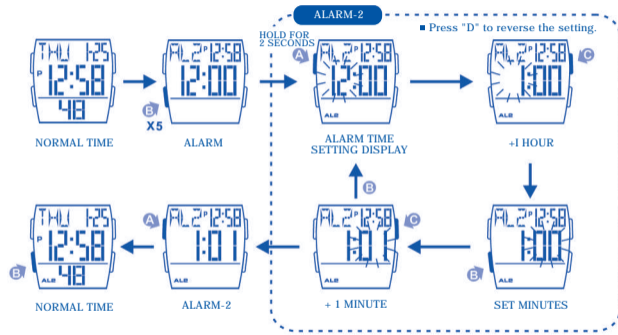
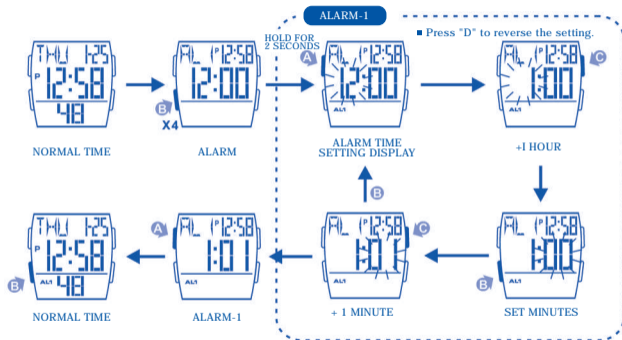

English

6. HOW TO USE ALARM 1 AND CHIME DISPLAY

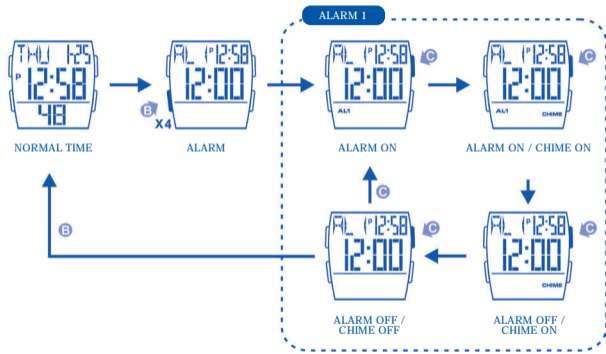

7. HOW TO SET ALARM 2 DISPLAY

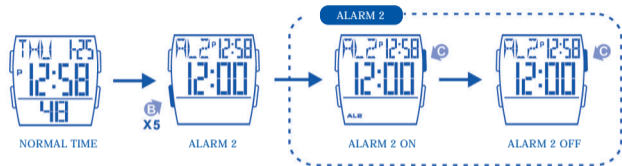

8. HOW TO SET THE CHRONOGRAPH



BEFORE 30 MINUTES

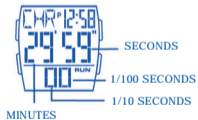

AFTER 30 MINUTES

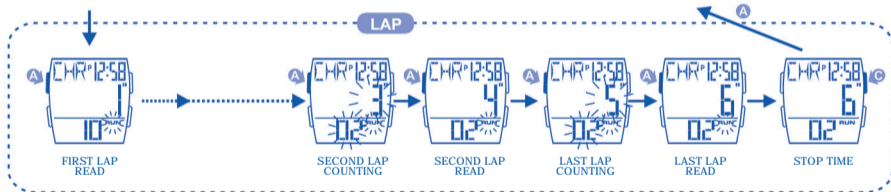
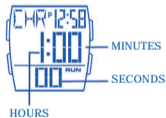

9. HOW TO SET TIMER

SET TIMER



NORMAL TIME



TIMER

HOLD FOR 2 SECONDS



SET HOURS



+1 HOUR



SET MINUTES



+1 MINUTE



SET SECONDS



+1 SECOND

■ Press "D" to reverse the setting.

When the timer reaches zero, the alarm will sound three beeps "BI-BI-BI" for 10 seconds. You can silence the alarm by pressing ant bottom. If not then it will count up to 5 minutes.

COUNT UP

During the last 10 seconds of the countdown, the alarm will beep once (BI) per second.

■ By pressing C button to start and stop



BI-BI



BI-BI



BI-BI-BI



BI



BI



BI



START

TIMER

10. HOW TO SET WORLD TIME

English

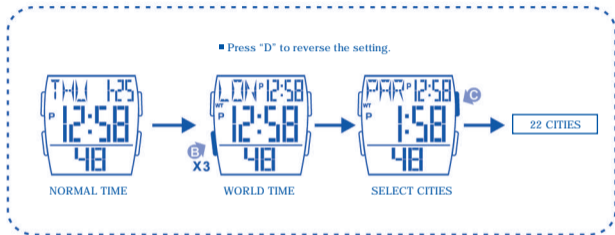

GMT Difference	-11	-10	-09	-08	-07	-06	-05	-04	-03	-00	+01	+02	+03	+04	+05	+06	+07	+08	+09	+10	+11	+12
CITY CODE	PPG	HNL	ANC	LAX	DEN	MEX	NYC	CCS	RIO	LON	PAR	CAI	MOW	DXB	KHI	DAC	BKK	HKG	TYO	SYD	NOU	WLG
CITY NAME	Samoa	Honolulu	Anchorage	Los Angel	Denver	Mexico	New York	Caracas	Rio De Janeiro	London	Paris	Cairo	Moscow	Dubai	Karachi	Dacca	Bangkok	Hong Kong	Tokyo	Sydney	Noumea	Wellington

English

11. CARE OF YOUR WATCH

- 1) This watch contains precise electronic components. Never attempt to open the case or remove the back cover.
- 2) Do not operate push buttons below the surface of the water when swimming or diving.
- 3) Should water or condensation appear in the watch, immediately have the watch checked. Water can corrode electronic parts inside the case.
- 4) Avoid severing impact: The watch is designed to withstand impact under normal use. It is inadvisable to subject it to severe impact of rough usage or drops onto hard surfaces.
- 5) Avoid exposing the watch to temperature extremes.
- 6) Clean the watch with a soft cloth and clean water only. Avoid using chemicals, especially soap.
- 7) Keep your watch away from strong electric field and static electricity.

12. FEATURES AND SPECIFICATIONS

- 1) Standard display mode: Hour, minutes, seconds, month, day of week.
- 2) Function:
 - Year, month, date AM/PM and Electro-Luminiscent light.
 - Alarm function with buzzer signal output.
 - Chronograph function with lap operation.
 - Hourly chime.
 - 12/24 hour format switch option.
 - World time.
 - Timer.
 - Second time zone.
- 3) Accuracy at normal temperature (25°C): ± 30 seconds a month.
- 4) Normal operating temperature range: 10°C - 40°C



By virtue of the regulations pursuant to the handling of waste products deriving from electronic and electrical equipment, end of lifecycle watch making products must be selectively collected for processing. You may therefore dispose of your quartz watch making products at any of our retail outlets or any other authorized collection point. The selective collection, processing, rating and recycling of these products helps contribute to safeguarding the environment and protecting our health.

1. AFFICHAGE NORMALE ET BOUTON D'UTILISATION

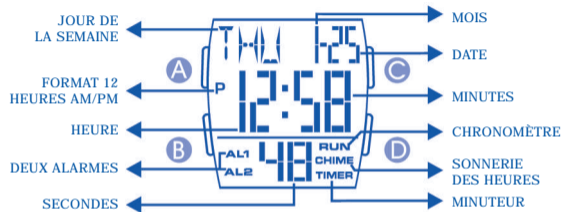

BOUTONS D'UTILISATION

A RÉGLAGE
B MODE

C ADJUSTMENT, MARCHE/ARRETÊR
D LUMIÈRE / INVERSER

2. COMMENT CHANGER LE MODE D’AFFICHAGE

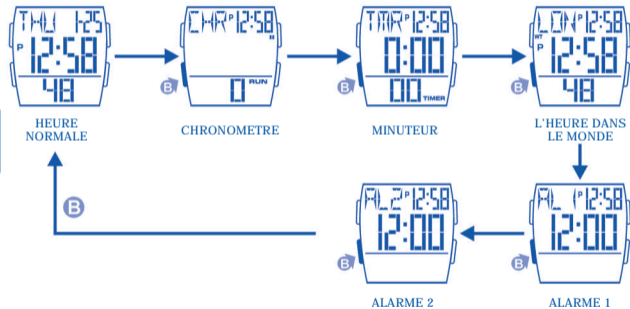

3. COMMENT ALUMER LA LUMIÈRE ÉLECTRO-LUMINESCENTE

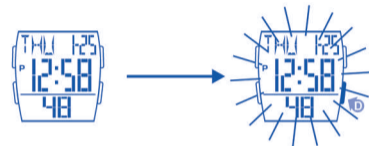

NOTE:

- 1) La lumière de fond de cette montre utilise une lumière électro-luminescente (EL), cette montre a tendance à perdre de sa puissance de luminosité après un très long usage.
- 2) La luminosité de la lumière de fond peut être difficile à distinguer sous les rayons directs du soleil.

4. COMMENT RÉGLER L'HEURE NORMALE

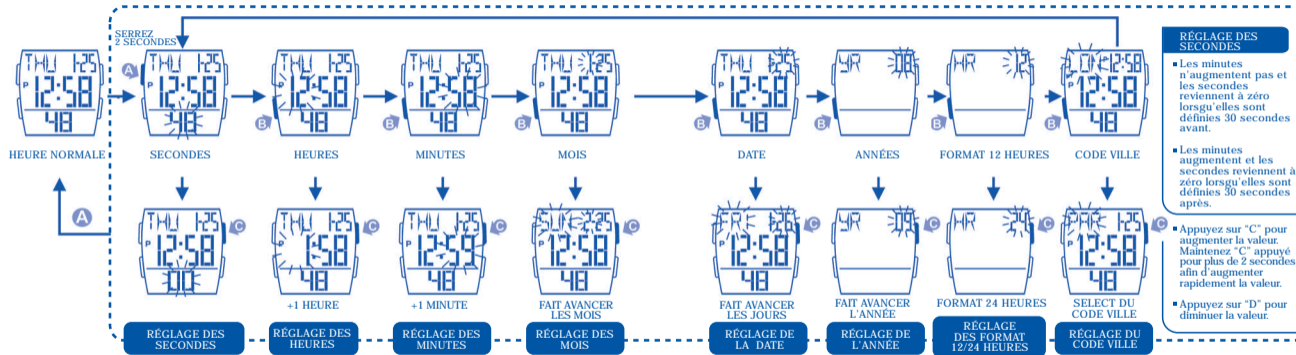

5. COMMENT RÉGLER L'ALARME

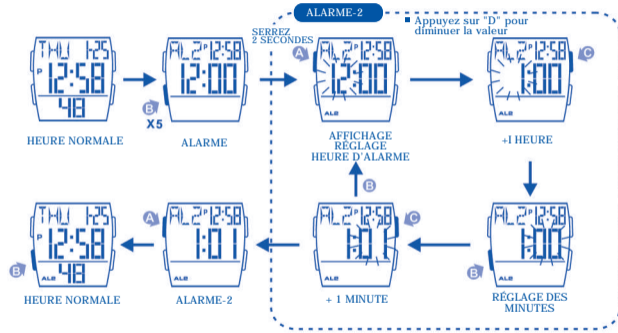
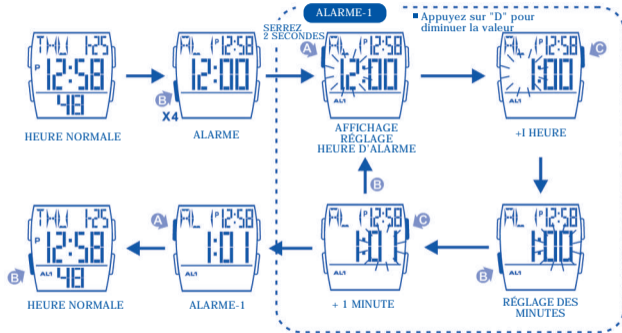

6. COMMENT UTILISER L’AFFICHAGE ALARME-1 ET CARILLON

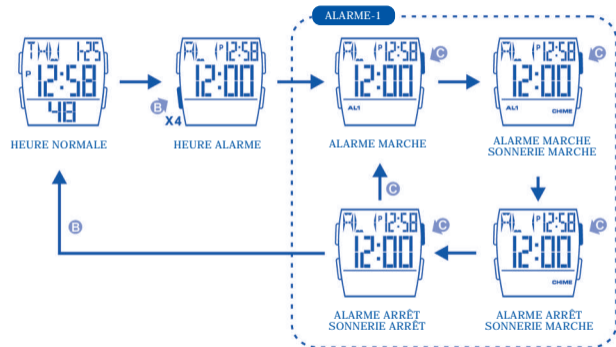

7. COMMENT RÉGLER L’AFFICHAGE ALARME-2

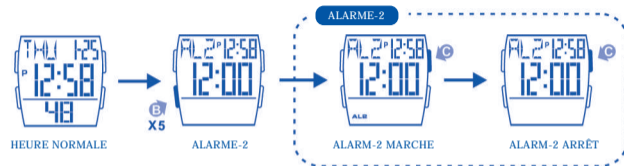

8. COMMENT UTILISER LE CHRONOMÈTRE



AVANT 30 MINUTES

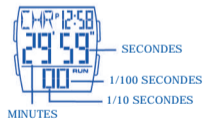

APRÈS 30 MINUTES

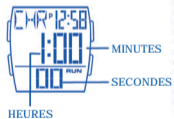

FONCTION TEMPS INTERMEDIAIRE

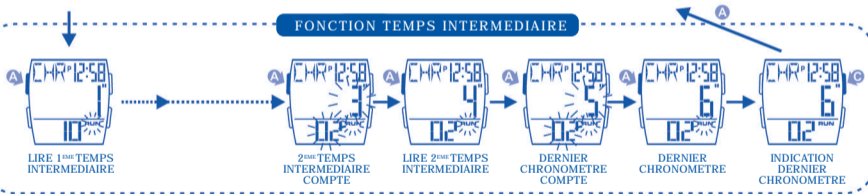

9. POUR UTILISER LE MINUTEUR DU COMPTE A REBOURS

POUR REGLER LE MINUTEUR DE COMPTE A REBOURS



Lorsque le minuteur atteint zéro, l'alarme produira trois bip sonores "BIP-BIP-BIP" pendant six secondes. Vous pouvez éteindre l'alarme en appuyant sur n'importe quel bouton. Sinon, elle continuera de sonner pendant 5 minutes.

DÉCOMPTE

Pendant les 10 dernières secondes du décompte, l'alarme ne produira qu'un bip (BIP) par seconde.

■ Appuyer sur le bouton "C" pour démarrer ou stopper.

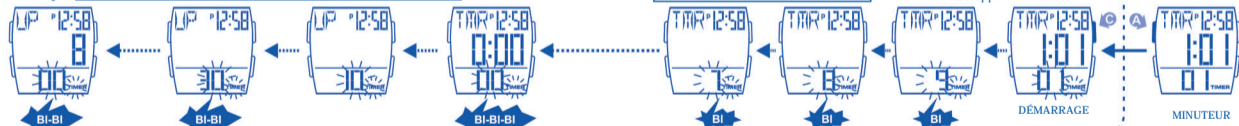

10. COMMENT RÉGLER L'HEURE DANS LE MONDE

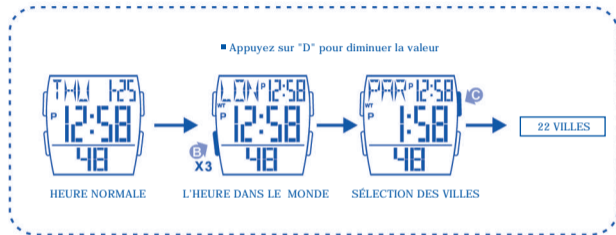

Différence GMT	-11	-10	-09	-08	-07	-06	-05	-04	-03	-00	+01	+02	+03	+04	+05	+06	+07	+08	+09	+10	+11	+12
CODE VILLE	PPG	HNL	ANC	LAX	DEN	MEX	NYC	CCS	RIO	LON	PAR	CAI	MOW	DXB	KHI	DAC	BKK	HKG	TYO	SYD	NOU	WLG
NOM DE VILLE	Samoa	Honolulu	Anchorage	Los Angel	Denver	Mexico	New York	Caracas	Rio De Janeiro	London	Paris	Cairo	Moscow	Dubai	Karachi	Dacca	Bangkok	Hong Kong	Tokyo	Sydney	Noumea	Wellington

11. ENTRETIEN DE VOTRE MONTRE

- 1) Cette montre contient des composants électroniques de précision. Ne jamais tenter d'ouvrir le boîtier ou d'enlever le couvercle arrière.
- 2) Ne pas pousser les boutons sur l'eau ou lorsque vous nager ou faites de la plongée.
- 3) Si de l'eau ou de la condensation apparaît à l'intérieur de la montre, faites la vérifier immédiatement. L'eau peut corroder les parties électroniques à l'intérieur de boîtier.
- 4) Éviter les chocs violents. Cette montre est conçue pour résister à des chocs occasionnés par un usage normal, il n'est pas recommandé tomber sur une surface dure.
- 5) Éviter d'exposer cette montre à des températures extrêmes.
- 6) Nettoyer la montre avec un chiffon doux et de l'eau propre uniquement. Éviter d'utiliser des produits chimiques, en particulier le savon.
- 7) Tenir la montre éloignée des fortes conditions de champ électrique et d'électricité statique.

12. CARACTÉRISTIQUES ET SPÉCIFICATIONS

- 1) Mode d'affichage standard: Heures, minutes, mois, date, jour de la semaine, PM.
- 2) Fonctions:
 - Années, mois, jour AM/PM et lumière électroluminescente.
 - Fonction alarme avec signal sonnerie.
 - Fonction Chronomètre avec fonction mesure au tour.
 - Carillon horaire.
 - Sélecteur de format 12/24 heures.
 - L'heure dans le monde.
 - Deuxième zone d'heure.
 - Minuteur.
- 3) Précision à une température normale (25°C) ± 30 seconds par mois.
- 4) Température limites pour un usage normale: 10°C - 40°C



En application de la réglementation sur les déchets des équipements électriques et électroniques, les produits horlogers à quartz en fin de vie font l'objet d'une collecte sélective en vue de leur traitement. Vous pouvez ainsi déposer nos produits horlogers à quartz dans l'un de nos points de vente agréés, ainsi que dans tout point de collecte habilité. La collecte sélective, le traitement, la valorisation et le recyclage contribuent à la sauvegarde de notre environnement et à la protection de notre santé.

1. GEWÖHNLICHE ANZEIGE UND KNOPFFUNKTIONEN

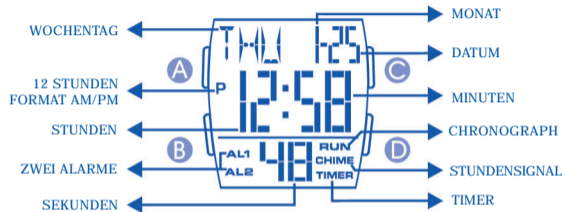

KNOPFGEBRAUCH

- | | |
|---------|--------------------------|
| Ⓐ SET | Ⓒ EINSTELLEN, START/STOP |
| Ⓑ MODUS | Ⓓ LICHT/UMGEKEHRT |

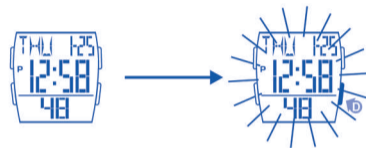
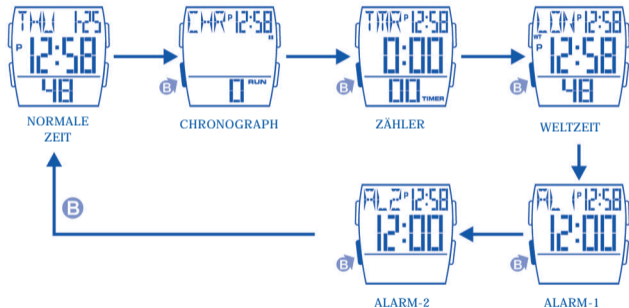

BEACHTEN SIE:

- 1) Die Beleuchtung der Uhr erfolgt durch ein elektrisch-lumineszierendes (EL) Licht. Die Uhr neigt nach sehr langer Benutzung dazu, die Beleuchtungskraft zu verlieren.
- 2) Die Beleuchtung der Uhr könnte schwer zu sehen sein, wenn unter sein, wenn unter direktem Sonnenlicht daraufgeschaut wird.

4. DAS EINSTELLEN DER NORMALE ZEIT

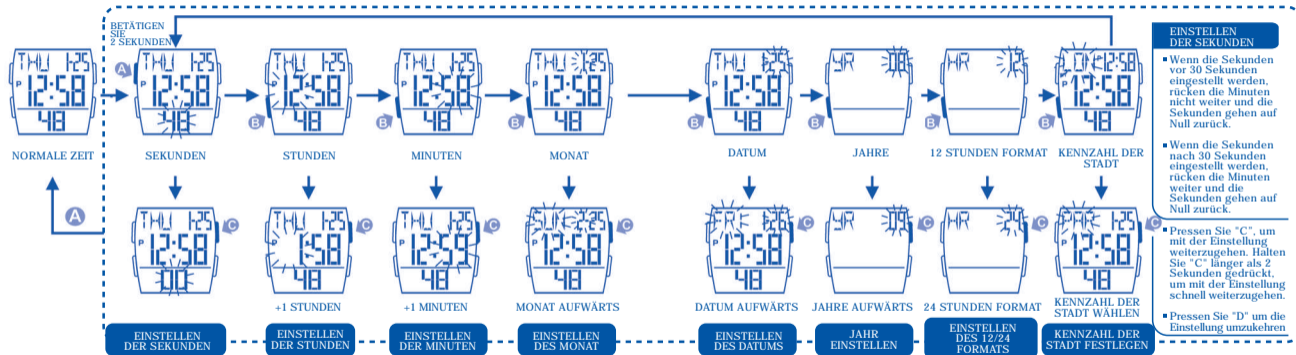

5. DAS EINSTELLEN DER ALARMZEIT

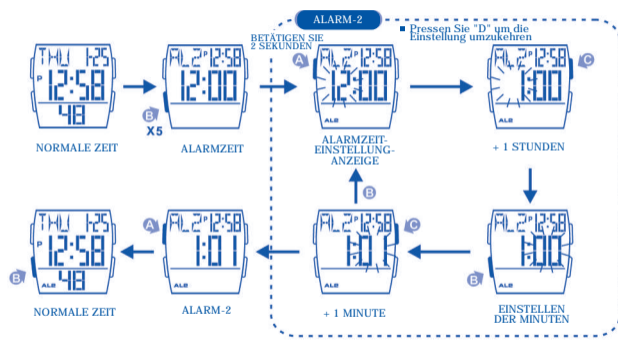
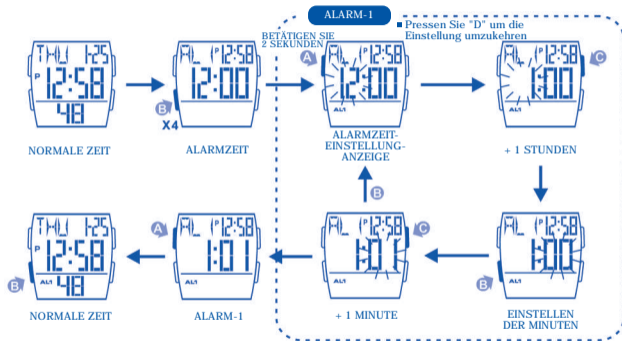

6. ALARMZEIT-ANZEIGE 1 UND STUNDENLÄUTEN-INDIKATOR

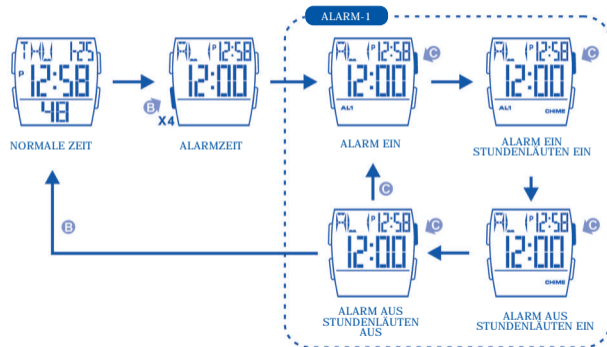

7. WIE STELLT MAN ALARM-2 EIN

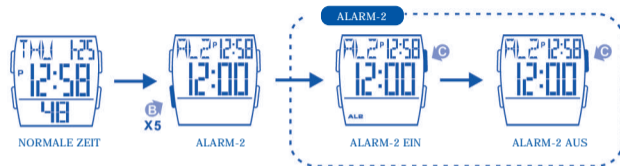

8. DIE BENUTZUNG DES CHRONOGRAPH

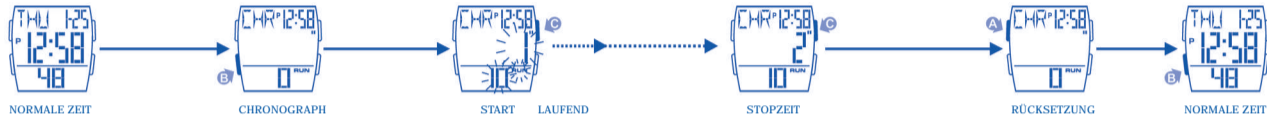

VOR 30 MINUTEN



NACH 30 MINUTEN

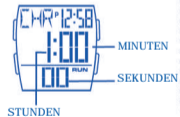

RUNDENZEIT

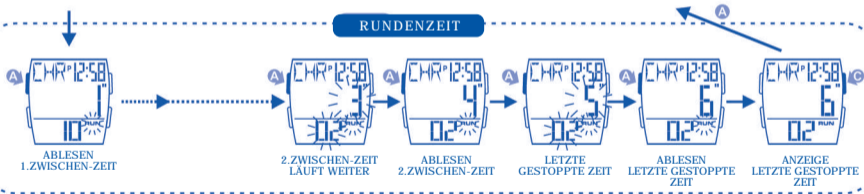

9. DAS EINSTELLEN DES COUNTDOWN ZÄHLERS

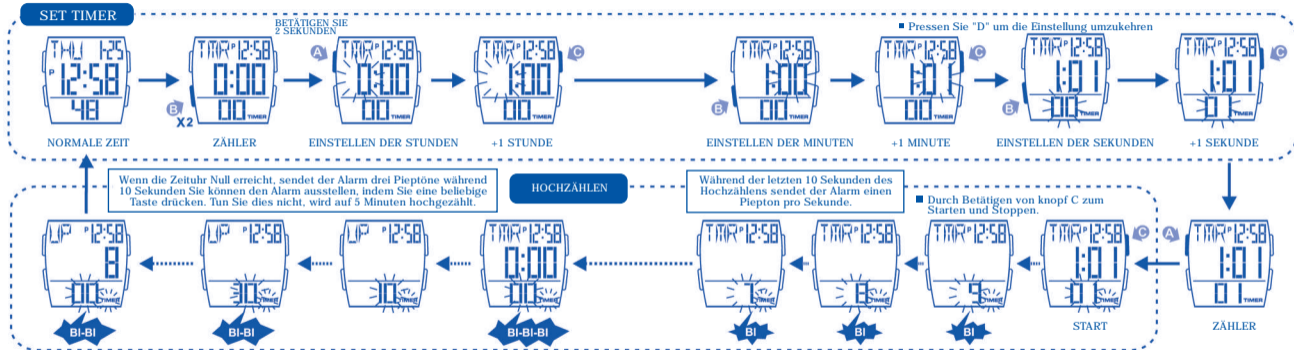

10. WIE STELLT MAN DIE WELTZEIT EIN

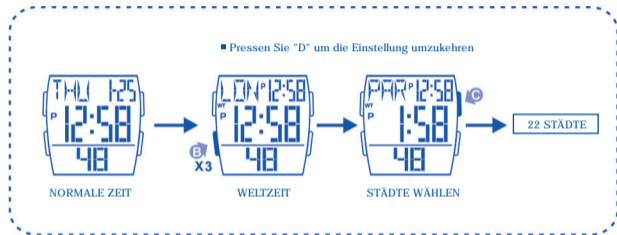

Unterschied zur GMT	-11	-10	-09	-08	-07	-06	-05	-04	-03	-00	+01	+02	+03	+04	+05	+06	+07	+08	+09	+10	+11	+12
KENNZAHL DER STADT	PPG	HNL	ANC	LAX	DEN	MEX	NYC	CCS	RIO	LON	PAR	CAI	MOW	DXB	KHI	DAC	BKK	HKG	TYO	SYD	NOU	WLG
NAME DER STADT	Samoa	Honolulu	Anchorage	Los Angel	Denver	Mexico	New York	Caracas	Rio De Janeiro	London	Paris	Cairo	Moscow	Dubai	Karachi	Dacca	Bangkok	Hong Kong	Tokyo	Sydney	Noumea	Wellington

- 1) Diese Uhr verfügt über präzise elektronische Komponenten. Versuchen Sie niemals, das Gehäuse zu öffnen oder den Deckel der Rückseite zu entfernen.
- 2) Betätigen Sie die Knöpfe nicht unter Wasser während dem Schwimmen oder Tauchen.
- 3) Sollte Wasser oder Kondensierung in der Uhr auftauchen, lassen Sie sie bitte sofort überprüfen, Feuchtigkeit kann Korrosion der elektrischen Teile verursachen.
- 4) Verhindern Sie harte Stöße. Die Uhr ist geeignet, nur Stößen unter normalen Bedingungen standzuhalten. Es wird nicht empfohlen, sie übermäßig starken Stößen oder grober Behandlung auszusetzen oder sie auf harte Oberflächen fallen zu lassen.
- 5) Vermeiden Sie es, die Uhr extremen Temperaturen auszusetzen.
- 6) Reinigen Sie die Uhr nur mit einem sanften Tuch und sauberem Wasser. Vermeiden Sie Chemikalien, insbesondere Seife.
- 7) Halten Sie Ihre Uhr fern von Umgebungen mit starkem Elektrofeld und statischer Elektrizität.

- 1) Normalzeit-Anzeige-Modus: Stunden, Minuten, Sekunden, Monat, Wochentag, Datum, Nachmittag "PM"
- 2) Funktionen:
 - Jahr, Monat, Datum AM/PM und Elektro- Lumineszenz-Anzeigebeleuchtung.
 - Alarmfunktionen mit Summer-Signal.
 - Stoppuhr-Funktionen mit Zwischenzeit-Abfahme.
 - Stundenläuten-Signal.
 - 12/24 Stunden Anzeigeformate wählbar.
 - Zähler
 - Weltzeit
 - Zweite Zeitzone.
- 3) Genauigkeit unter normalen Temperaturen: ± 30 s/Monat.
- 4) Normalgebräuchlicher Temperaturbereich: 10 -40 Grad Celsius.



Gemäß den Bestimmungen über die Behandlung von Abfällen durch Elektronik- und Elektro-Altgeräte sind Quarzuhrenprodukte, deren Lebensdauer abgelaufen ist, selektiv zu sammeln, um sie dem Recycling zuzuführen. Sie können Ihre Quarzuhrenprodukte daher in einer unserer Verkaufsstellen oder an einer beliebigen Sammelstelle abgeben. Die selektive Sammlung, die Verarbeitung, die Bewertung und das Recycling dieser Produkte ist ein Beitrag zum Umweltschutz und zum Schutz unserer Gesundheit.

1. FUNZIONI ED INDICAZIONI SULLO SCHERMO

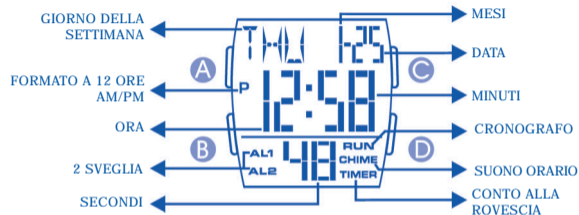

FUNZIONI DEI PULSANTI

- A** REGOLAZIONE
- B** MODO

- C** MODIFICARE START/STOP
- D** LUCE / INVERSO

2. PER CAMBIARE LE FUNZIONI SUL DISPLAY

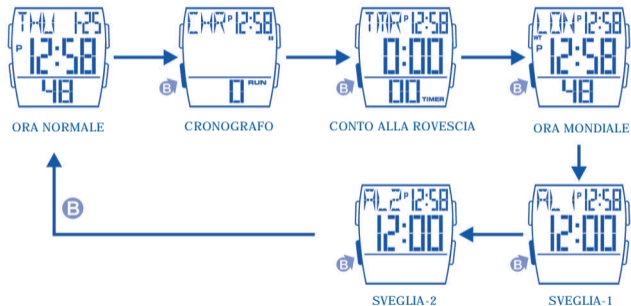

3. PER UTILIZZARE LA LUCE

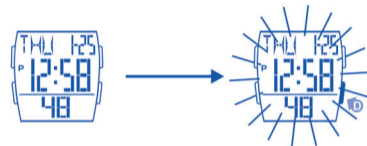

NOTARE:

- 1) L'orologio è dotato di retroilluminazione elettroluminescente (EL), che si può affievolire con l'uso in un periodo di tempo prolungato.
- 2) Se esposto direttamente alla luce del sole, la luce prodotta dalla retroilluminazione può non essere evidente.

4. PER REGOLARE L'ORA NORMALE

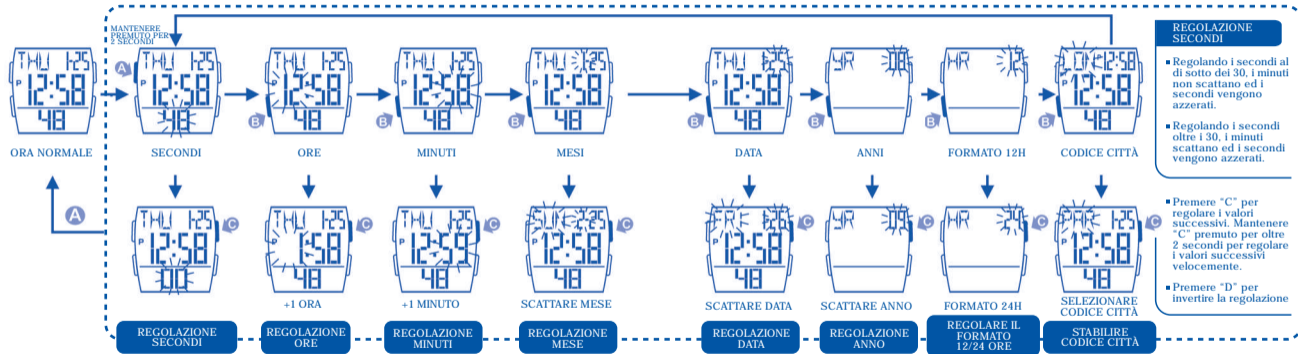

5. PER METTERE LA SVEGLIA

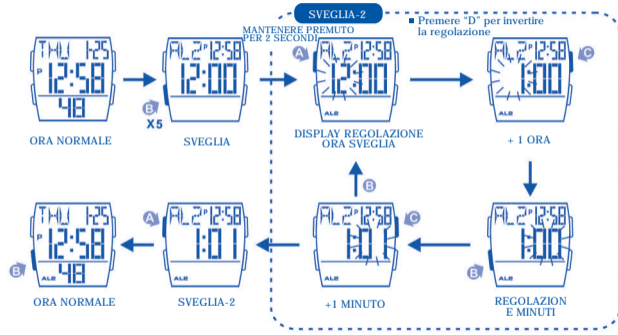
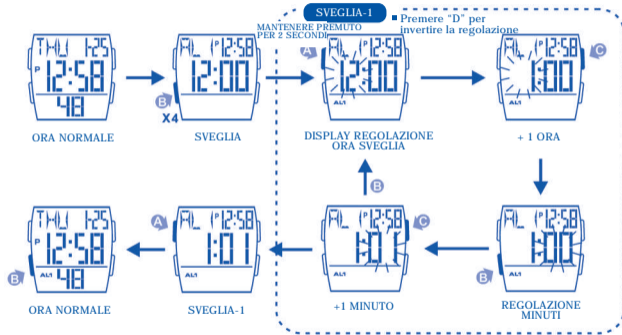

6. PER UTILIZZARE IL DISPLAY SVEGLIA-1 E SONERIA

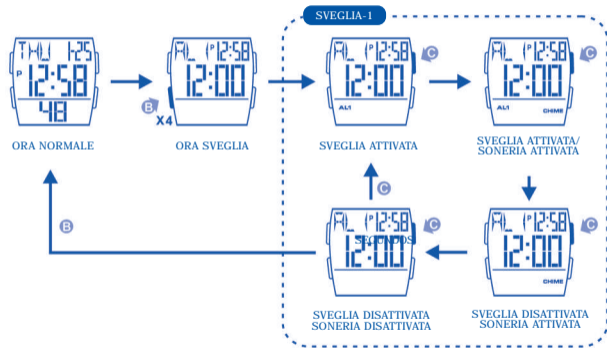

7. REGOLAZIONE DISPLAY SVEGLIA-2



8. PER UTILIZZARE IL CRONOGRAFO



PRIMA DI 30 MINUTI



DOPO 30 MINUTI

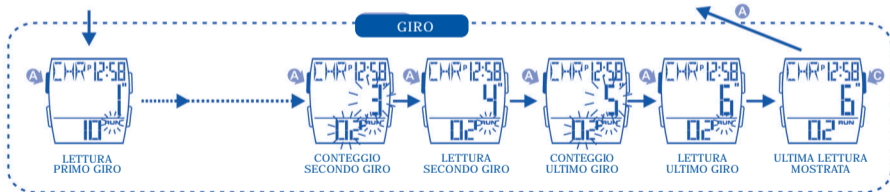
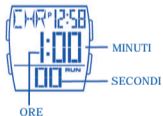

9. PER UTILIZZARE IL CONTO ALLA ROVESCIA

REGOLAZIONE TIMER



Quando il timer raggiunge lo zero l'allarme emette tre avvisi sonori: "Bi-Bi-Bi" della durata di 10 secondi. Spegner l'allarme premendo qualsiasi pulsante; in caso contrario verrà effettuato il conteggio progressivo fino ad un massimo di 5 minuti.

CONTEGGIO PROGRESSIVO

Durante gli ultimi 10 secondi del conteggio regressivo l'allarme emetterà un avviso sonoro (BI) al secondo.

■ Premendo il pulsante C per dare lo start e lo stop

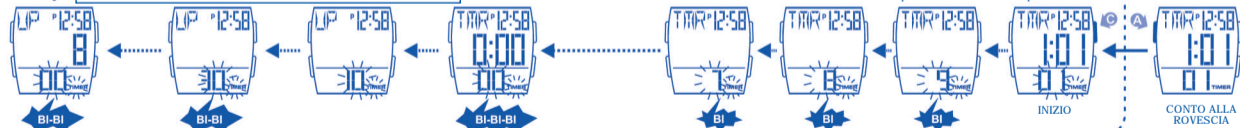

10. REGOLAZIONE ORA MONDIALE

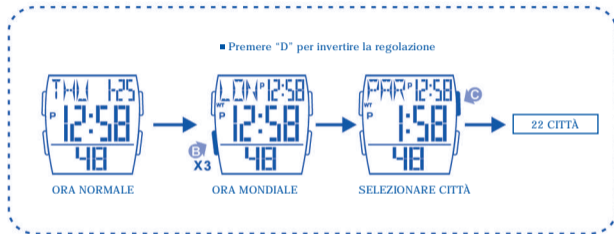

Differenza fuso (GMT)	-11	-10	-09	-08	-07	-06	-05	-04	-03	-00	+01	+02	+03	+04	+05	+06	+07	+08	+09	+10	+11	+12
CODICE CITTÀ	PPG	HNL	ANC	LAX	DEN	MEX	NYC	CCS	RIO	LON	PAR	CAI	MOW	DXB	KHI	DAC	BKK	HKG	TYO	SYD	NOU	WLG
NOME CITTÀ	Samoa	Honolulu	Anchorage	Los Angel	Denver	Mexico	New York	Caracas	Rio De Janeiro	London	Paris	Cairo	Moscow	Dubai	Karachi	Dacca	Bangkok	Hong Kong	Tokyo	Sydney	Noumea	Wellington

11. PRECAUZIONI PER IL VOSTRO OROLOGIO

- 1) Questo orologio contiene precise componenti elettroniche. Non provare, in nessuna circostanza, ad aprire la cassa o a rimuovere il coperchio posteriore.
- 2) Non utilizzare i pulsanti sotto della superficie dell'acqua, nuotando o in immersione.
- 3) In caso di acqua o condensa nel quadrante fare controllare l'orologio immediatamente. L'acqua può esercitare un'azione corrosiva sulle componenti elettroniche contenute nella cassa.
- 4) Non sottoporre l'orologio a forti impatti. L'orologio è stato studiato per un uso ordinario e resiste quindi a condizioni di normale impatto. Non sottoporre l'orologio a forti impatti, non farne un uso brusco e non lasciarlo cadere su superfici dure.
- 5) Non esporre l'orologio a temperature estreme.
- 6) Pulire l'orologio esclusivamente con un panno morbido e acqua pulita. Evitare l'uso di prodotti chimici, soprattutto sapone.
- 7) Mantenere l'orologio lontano da forti campi magnetici e da luoghi dove sia presente elettricità statica.

12. CARATTERISTICHE TECNICHE

- 1) Display Standard: Ore, minuti, secondi, mese e giorno della settimana.
- 2) Operazione dei pulsanti:
 - Anno, mese, data, AM/PM, luce elettroluminescente.
 - Sveglia con avvisatore sonoro.
 - Funzione di cronografo con contagiri.
 - Soneria ora.
 - Opzione del formato 12/24 ore.
 - Ora mondiale.
 - Conto alla rovescia.
 - Secondo fuso orario.
- 3) Precisione a temperatura normale (25°): ± 30 secondi al mese.
- 4) Oscillazione di temperatura normale: 10°C -40°C.



Ai sensi dei regolamenti relativi alla manipolazione dei rifiuti provenienti da assemblaggi elettrici ed elettronici, i prodotti d'orologeria ormai inutilizzabili devono essere raccolti separatamente per consentirne il trattamento. In qualsiasi nostro punto vendita o punto di raccolta autorizzato troverà gli appositi contenitori per lo smaltimento dei componenti del Suo orologio al quarzo. La raccolta differenziata, il trattamento, la valorizzazione ed il riciclaggio di tali prodotti contribuiscono alla salvaguardia dell'ambiente ed alla produzione della nostra salute.